

HOMEOffice

Complete

Cable Lead

USER MANUAL

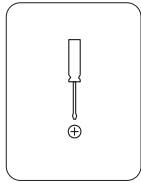

Components

Phillips Washer Head
Self Tapping Screw (4)

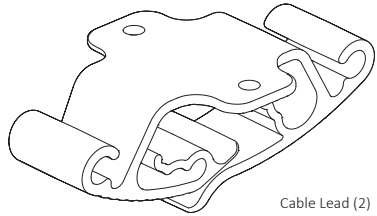

Cable Lead (2)

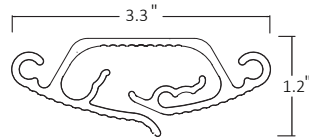

WARNING: When installing and using the product, act with care not to over bend to prevent breakage.

STEP 1: Choose the most desirable place for the Cable Lead.

STEP 2: Take two screws and screw the Cable Lead onto the underside of your desk.

STEP 3: Place the cables through the opening on the Cable Lead and push them into the canals of the Cable Lead.

STEP 4: You can use the canals on the left and the right side of the Cable Lead.

NOTE: See the other side of this page how you can use the Cable Lead in many different Wire Management arrangements.

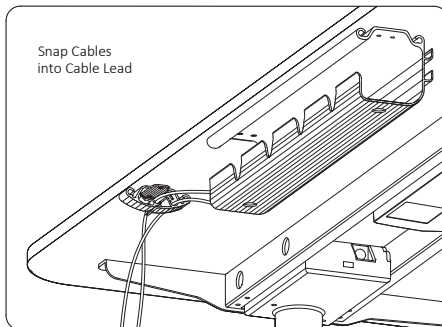
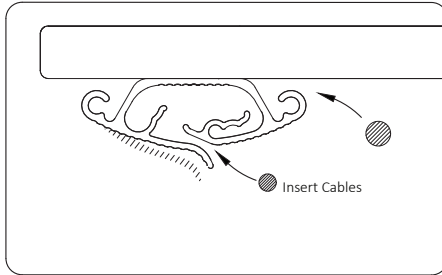

WARNING: To be installed on Desk Tops with a minimum thickness of 3/4"

HOMEOffice

Complete

Cable Lead

USER MANUAL

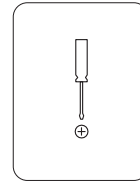

Components

Phillips Washer Head
Self Tapping Screw (4)

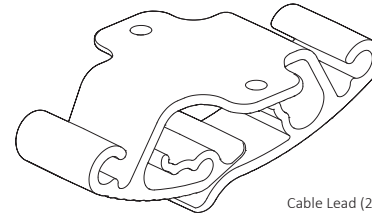

Cable Lead (2)

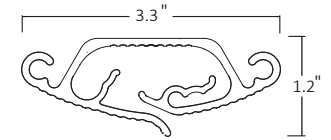

WARNING: When installing and using the product, act with care not to over bend to prevent breakage.

STEP 1: Choose the most desirable place for the Cable Lead.

STEP 2: Take two screws and screw the Cable Lead onto the underside of your desk.

STEP 3: Place the cables through the opening on the Cable Lead and push them into the canals of the Cable Lead.

STEP 4: You can use the canals on the left and the right side of the Cable Lead.

NOTE: See the other side of this page how you can use the Cable Lead in many different Wire Management arrangements.

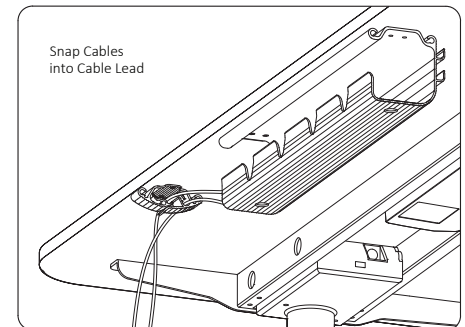
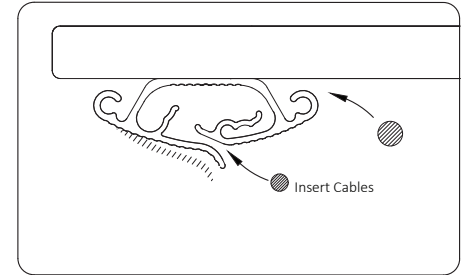

WARNING: To be installed on Desk Tops with a minimum thickness of 3/4"

Sample Applications



From a desk wire management Tray to a Cable conduit.



From a desk wire management Tray to a Mesh tube.

Sample Applications



From a desk wire management Tray to a Cable conduit.



From a desk wire management Tray to a Mesh tube.



Securing cables from point A to point B.



Secure cables from a side desk to a main desk.



Securing cables from point A to point B.



Secure cables from a side desk to a main desk.



Training Room, managing cables from desk to desk.



Meeting Table, managing cables from table to floor.



Training Room, managing cables from desk to desk.



Meeting Table, managing cables from table to floor.